

Note: Use when inlet diameter of main line is 33" or less.

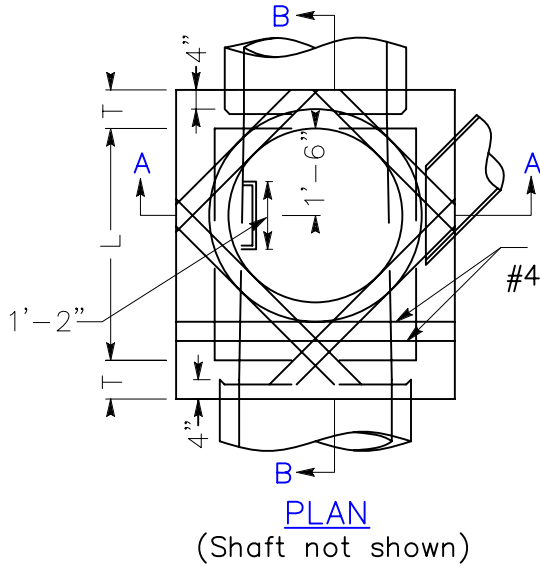

All steel reinforcement  
#4 deformed bars  
at 4" OC.

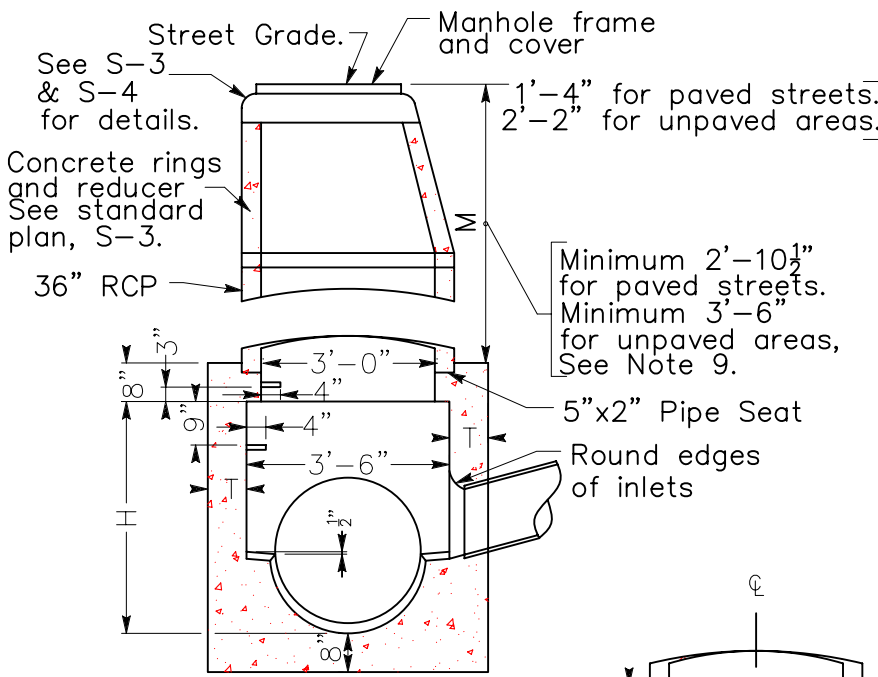
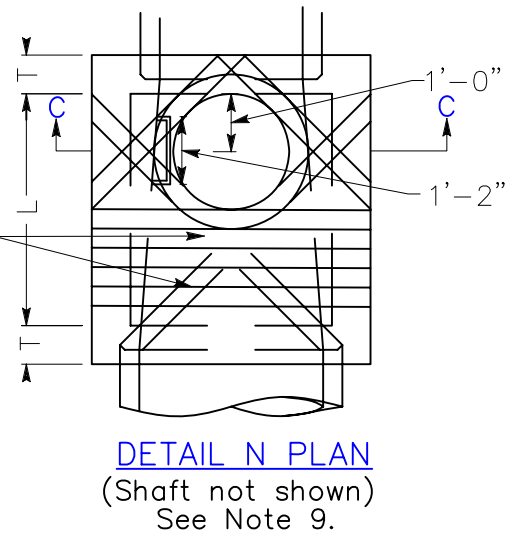

SECTION A-A

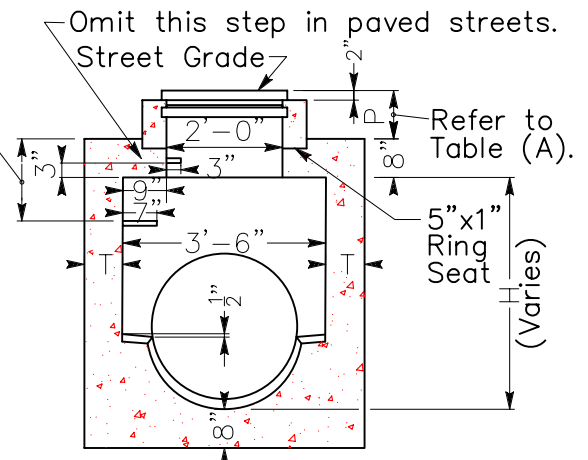

SECTION C-C

TABLE (A)

	Max.	Min.
For paved streets.	11"	8 1/2"
For unpaved areas.	16"	15"

See Note 10.

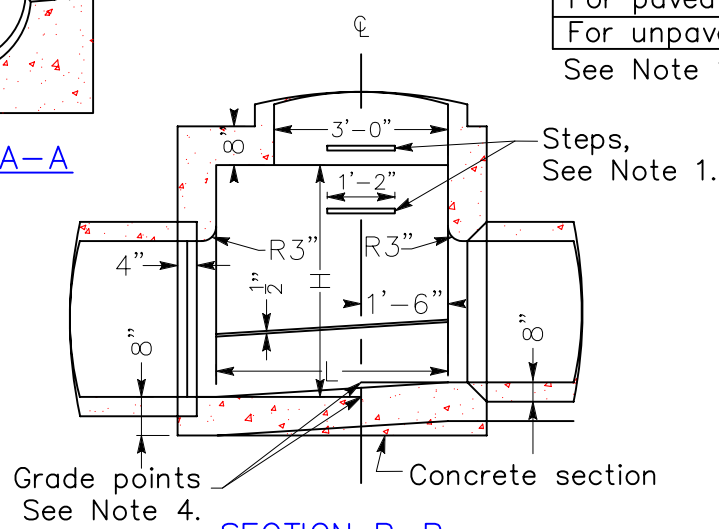

SECTION B-B

See sheet 2 for notes.

Not to Scale



*[Signature]*  
City Engineer

01/16/07  
Date

NO	BY	DATE	REVISION
△			
△			
△			

SHEET  
1 of 2



STANDARD  
STORM DRAIN  
MANHOLE TYPE 1

S-1

NOTES

1. Steps shall be  $\frac{3}{4}$ " round galvanized steel and anchored not less than 6" in the walls of structures. Unless otherwise shown, steps shall be spaced 12" OC. The lowest step shall be not more than 2'-0" above the ledge at side of manhole floor. Steps may be  $\frac{1}{2}$ " steel with polypropylene plastic coating conforming to State Standard Plan D74C. All steps shall be cast-in-place.
2. Concrete shall be class "A".
3. Reinforcing steel shall be #4, deformed, bars. Wall reinforcing not required when (H) + (M) = 8'-0" or less and the unsupported width or length equals 7'-0" or less. Walls exceeding these limits shall be reinforced with #4 bars at 18" OC placed  $1\frac{1}{2}$ " clear to inside of box unless otherwise shown.
4. Stations of manholes shown on improvement plan apply at center line of shaft. Elevations are shown at shaft center and refer to the prolonged invert grade lines.
5. Floor of manhole shall be steel-troweled.
6. Rings, reducer and pipe for access shaft shall be seated in mortar and neatly pointed or wiped inside shaft.
7. Length (L) shall be 4'-0" unless otherwise shown on improvement plan. (L) may be increased or location of manhole shifted to meet pipe ends, at the option of contractor. Any changes of manhole location require City Engineer approval.
8. Height (H) (in sections A-A and B-B) shall not be less than 4'-0" but may be increased at option of contractor, provided that the value of (M) shall be not less than the minimum specified and that the reducer shall be used. For (H) in section C-C see note 10.
9. Shaft shall be constructed as per section C-C and detail "N" when depth (M) from street grade to top of box is less than 2'-10 $\frac{1}{2}$ " for paved streets or 3'-6" for unpaved areas.
10. Depth (P) may be reduced to 6" when larger values of (P) would reduce (H) (in section C-C) to 3'-6" or less.
11. (T) shall be 8" for values of (H) up to and including 8'-0".  
(T) shall be 10" for values of (H) over 8'-0".

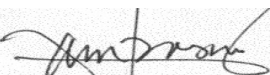
Not to Scale

	 City Engineer	01/16/07 Date				SHEET 2 of 2	STANDARD STORM DRAIN MANHOLE TYPE 1	S-1
			NO	BY	DATE			